

Portable Compressors

## Mobilair™ M220 and M270



### Tough, dependable unit

The Mobilair™ M220 and M270 are versatile units suited for a number of applications including road construction, mining, and back-up industrial plant air. Units are also well suited for rental houses and railroads.

The M220 and M270 offer a wide array of features that make them very user-friendly. Units come standard with an easy-to-read control panel that is well protected and visible from the outside. The fuel tank has a large filler neck with overflow protection for safe, easy filling. A height adjustable tow bar makes trans-

porting the units easy. Torsion bar suspension and oversized tires provide superior road handling.

### Unsurpassed durability and quietness

The M220 and M270's heavy-duty steel chassis and fully galvanized enclosure are built to withstand even the harshest conditions. Both the enclosure and solid steel flooring protect the motor, airend, and critical components from dirt and water. The enclosure is also super soundproofed and provides extremely quiet operation.

### Capacities:

from 750 to 950 cfm

### Pressures:

from 70 to 205 psig

### Standard Features:

- Sigma Profile rotary screw airend produces more air with less fuel consumption
- Heavy duty steel chassis
- Fully galvanized enclosure
- Access doors allows easy access to all maintenance points
- Solid steel floor for low noise and structural integrity
- Torsion bar suspension system for superior road handling and increased ground clearance
- Lockable access doors and instrument panel
- Lighting and bumper kit
- Heavy duty, liquid cooled, turbo-charged diesel engine complies with Tier 3 emissions standards

### Optional Features:

- Pressures up to 205 psig
- Filtration packages and aftercoolers
- Complete line of air tools
- Lubricators and separators
- Skid mounted units

- 1** Heavy duty bumpers and lighting kits are standard
- 2** High capacity cold start battery ensures reliable operation even under severe working conditions
- 3** Heavy duty, liquid cooled, turbo-charged diesel engine complies with Tier 3 emissions standards
- 4** Lifting eye for simple handling
- 5** 2 different axle configurations provide options for transport (twin axle shown)
- 6** Rigid pipes incorporate flexible connections and are leak proof
- 7** 4 micron, 2 stage compressor inlet filter with maintenance indicator
- 8** 10 micron spin-on oil filter with integral thermostatic valve
- 9** Sigma Profile rotary screw airend produces more air with less fuel consumption
- 10** Tow bar
- 11** Height adjustable hitch

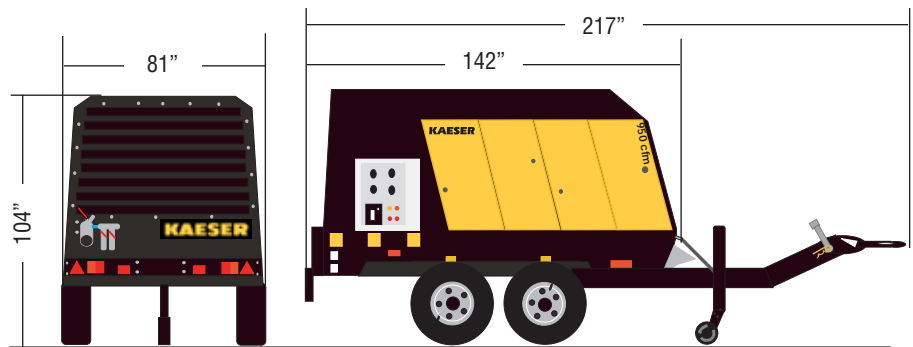
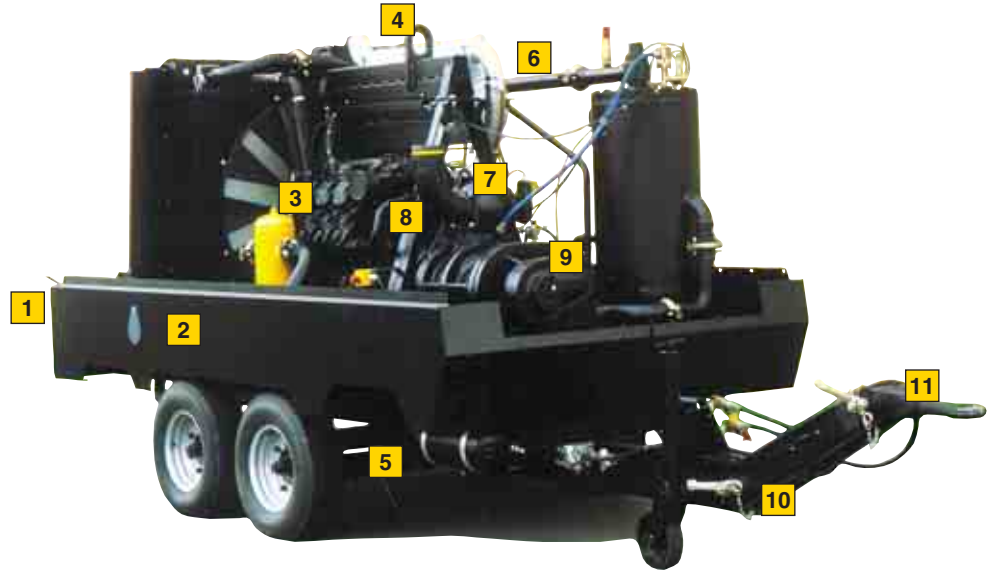

## Specifications

Compressor	M220	M270	Diesel Engine	M220	M270	Package	M220	M270
Free air delivery (cfm)	750	950	Make	BFGM1013FC Deutz	Mercedes Benz OM501LA	Fuel tank capacity (gal)	146	146
Working pressure (psig)	125	100	Power at full load (hp)	236	313	Weight, dry (lb.)	9203	9634
			Full load speed (rpm)	1700	1700	Sound level max.	76 db(A) at 23 ft.	
			Off load running speed (rpm)	1400	1200			

*Specifications are subject to change without notice.*

# KAESER COMPRESSORS

**Built for a lifetime.™**

Corporate Headquarters:  
P.O. Box 946  
Fredericksburg, Virginia 22404  
Phone 540-898-5500  
Fax 540-898-5520  
www.kaeser.com

Certified Management Systems



## The Air Systems Specialist

With over 85 years of experience, Kaeser is the air systems specialist. Our extensive 100,000 square foot facility allows us to provide unequalled product availability. With service centers nationwide and our 24-hour emergency parts guarantee, Kaeser customers can rely on the best after-sales support in the industry. Kaeser stands committed to providing the highest quality air system for your specific compressed air needs.